

**SYNERGY™**

 **3000**

The Power of SPC

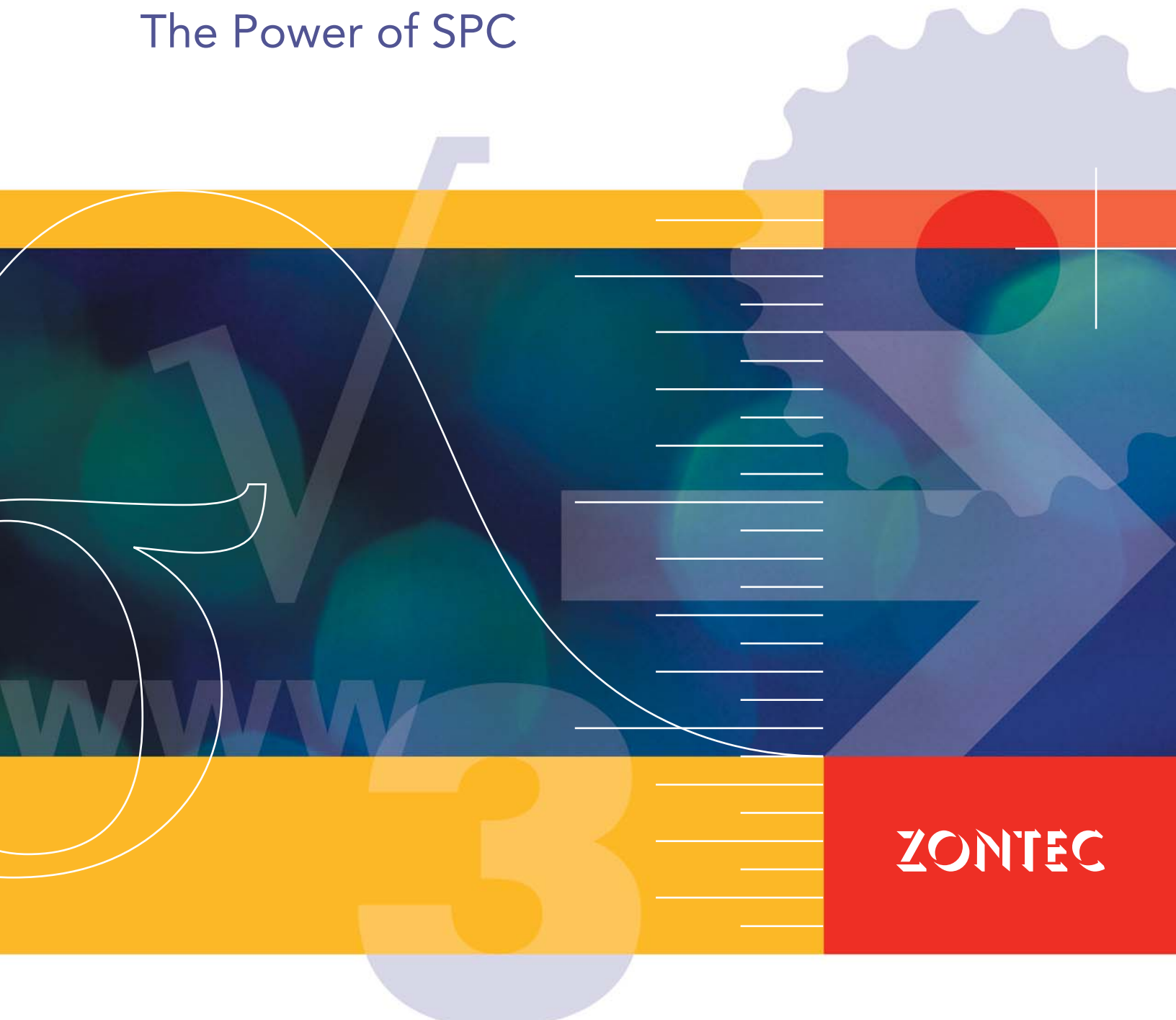

**ZONTEC**

Enterprise-Wide Statistical Process Control Software

# Synergy 3000 – Managing Global Supply Chain SPC Data in Real-Time

Manufacturers of today are striving to integrate all the data they are receiving from various applications into one cohesive view of their enterprise supply chain. With its cloud computing Microsoft .NET™ architecture, SQL database, and Web-based data entry and monitoring modules, Synergy 3000 is uniquely designed to help you continually improve your processes by eliminating scrap, reducing rework and increasing personnel's productivity. It also provides you an immediate, global

view to analyze the performance of your people, your processes, your production equipment and your suppliers worldwide. With access to real-time data, your team prevents defects before they occur and can verify for your customers that their specifications are met. This immediate, worldwide view of your Statistical Process Control (SPC) data also allows management to analyze ongoing business profitability.

## Designed for Each Level of User

In Synergy 3000, each level provides users their own view, access, privileges, charting and reporting capabilities:

**Administrator Level** – oversees SQL database setup, defines system access and security levels for users

**Operator Level** – enter data from the shop floor, from remote locations globally or supplier locations

**Manager Level** – monitor in real-time unlimited processes at multiple facilities including supplier locations

**Engineer Level** – populates the database with specific product/process information, defines data entry methods and analyzes results in real-time from the shop floor or from remote locations

## Synergy 3000 System Architecture

### Windows Platform

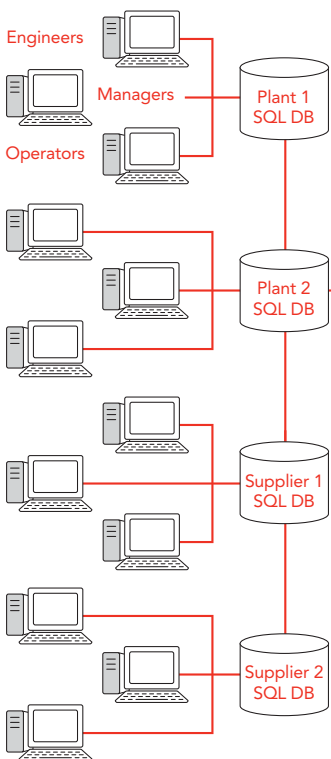

Configuration, Data Collection, Monitoring, Analysis, Reporting

### Web Platform



Web Operator Data Collection

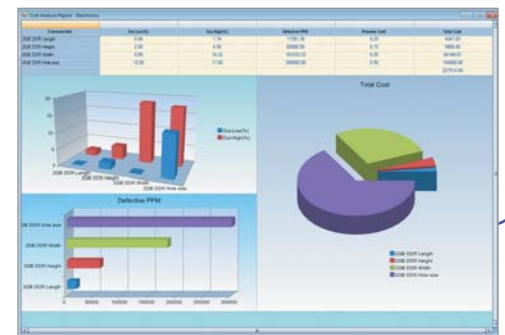



## Benefits for the System Administrator

Built with Microsoft .NET technology, Synergy 3000 contains an SQL database with a closed security system to prevent security breaches, halt malicious software and thwart hackers. The system administrator controls system access, data security, user privileges, data change logs, audit trails and password aging. These controls are important for highly regulated industries that maintain electronic records, file electronic reports, utilize EDI and must meet FDA regulations. Synergy 3000 is designed to satisfy the needs of industries regulated by the U.S. Food & Drug Administration who need to be in full compliance with Title 21 Code of Federal Regulations (CFR) Part 11. Synergy 3000 can be implemented with a unique electronic record/electronic signature that includes date/time-stamped audit trails, logging and tracking of changes to original data, password "aging" provisions and an electronic signature pad to digitally capture and display handwritten signatures alongside the SPC data. With this feature, individual signatures can confirm accountability for every quality control sample entered.

## Rapid Implementation and Training

Synergy 3000, like all of the Zontec products, is known for its rapid implementation. Customers routinely create Data Banks and Data Tables in minutes to build their database structure. "The program is efficient, fast and runs smoothly. I haven't seen an operator yet that didn't quickly learn how to use Synergy 3000," said Tim Stutzman, System Analyst for Oregon Freeze Dry, Inc. Customers have also found that operators without Statistical Process Control experience can easily adapt to Synergy 3000. "Using Synergy 3000, we are easily able to train our junior operators who do not have any SPC experience," said Fedele D'Alessandro, General Manager for LMPsrl.

*"The program is efficient, fast and runs smoothly. I haven't seen an operator yet that didn't quickly learn how to use Synergy 3000," said Tim Stutzman, System Analyst for Oregon Freeze Dry, Inc.*

## Industrial Leaders Choose Zontec

The superior scope and technical sophistication of Zontec products have made us the SPC vendor of choice for more than 5,000 companies around the world in virtually every industrial category. We define our success by our customers' high quality products and services.

3M  
Abbot  
Aircraft Precision  
Arcelar Mittal Dofasco  
Batesville Casket  
Bay Valley Foods  
Briggs & Stratton  
Brita  
Burt's Bees  
Cessna Aircraft  
Chicago Miniature Lighting LLC  
Clorox  
Conoco Phillips  
CR Bard  
Dimatix Fujifilm  
Foam Design  
G E Lighting  
General Dynamics  
Gerber  
Glad  
Grakon LLC  
Hidden Valley Ranch  
Kimberly-Clark  
Kingsford Products  
Kordsa  
LMPsrl  
Lockheed Martin  
LUK  
Malt-O-Meal  
Martinrea Industries, Inc.  
Multicircuits, Inc.  
Nestlé Purina Pet Care  
NSK Americas Steering  
Olympus Corp OSTA  
Oregon Freeze Dry Inc.  
Perfetti Van Melle  
Peterson Farms  
Pilot Chemical Company  
Portage Plastics Corporation  
Printpack Packaging Company  
Rubbermaid  
Stanley Black & Decker  
TDK-Phillipines Corporation  
Toyota Motor  
US Playing Card Company

## Easy Data Entry for Operators and Suppliers

Synergy 3000 provides multiple options for data entry including keyboards, mice (with on-screen key pad), key pads, touch screens and/or voice inputs. Data can also be collected automatically from gaging devices via COM port or wireless system. In addition, an optional Web Operator module can be utilized for data collection from other facilities and/or suppliers across the globe.

Several linking options are available in the Operator Level of Synergy 3000 to provide instant access to information relevant to successful data collection. Work instructions, control plans, product images, training videos and more can be accessed directly through the program.

Through the real-time, color-coded, interactive charts, operators can easily monitor data. This allows them to react immediately to trending data in order to make adjustments before an out-of-control or out-of-specification condition occurs. If additional information on previously collected data is needed, the operator simply clicks a plotted data point. If an out-of-control or out-of-specification condition occurs, the operator is immediately notified and automatic emails are sent to designated



individuals. Operators can also run reports to ensure they are meeting the required customer specifications. "We run 5 packaging lines a day with products running in the thousands. If we can reduce our range by a gram, that saves us a ton of money. Without Synergy 3000, we would not be able to set such tight tolerances," said Tim Stutzman, System Analyst for Oregon Freeze Dry, Inc.

### Data Integrity

As soon as data is entered into the system, it is automatically saved with a date and time stamp. Synergy 3000 also provides up to 12 unique identifiers (IDs) to attach to each sample entered. This feature is extremely useful to identify the lot, batch, line, machine, shift of the product sample and the operator collecting the data. The IDs also provide traceability, generate audit trails and facilitate contract compliance. A powerful query function allows you to search through previously collected data based on any combination of fields.

### Synergy 3000 Version 5 System Requirements

#### Server Specifications Computer

processor 1GHz or faster

1.0 GB RAM

10.0 GB available disk space  
1024 x 768 or higher resolution monitor

SQL Server Database Management System

Microsoft Windows® Server 2016, 2019, 2022

Microsoft .NET Framework 4.0  
Microsoft .NET Framework 4.0 SDK

Microsoft Internet Information Services

#### Client Specifications

Computer processor 1GHz or faster

1.0 GB RAM

3.0 GB available disk space  
1024 x 768 or higher resolution monitor

Microsoft Windows 7, 8, 10, 11

Internet Explorer 5.5 or higher

Microsoft .NET 4.0

Windows compatible printer

Optional – Gage(s) and/or multiplexer(s)



## Managers Enjoy Global, Real-Time Monitoring and Reporting

Managers around the globe can constantly monitor their entire supply chain process. The Manager Level real-time dashboard display provides status indicators for every process.

"We can have operators enter data in the plants across the globe, while engineers and managers can monitor the data anywhere in the world. Prior to implementing Synergy 3000, we could not easily get this worldwide perspective, in particular from our plant in China," said Don Bartlett, Director of Quality & Customer Service for Grakon LLC. Managers can instantly access charts, data sheets and log files for any process, and receive automatic emails if any out-of-control or out-of-specification condition occurs. They can customize, document and record reports that highlight various aspects of the production process. Reports by

*"We can have operators enter data in the plants across the globe, while engineers and managers can monitor the data anywhere in the world," said Don Bartlett, Director of Quality & Customer Service for Grakon LLC.*

summary, by reject or by data; all on a monthly, daily/weekly, sample or ID basis are also available. Managers can also run comprehensive traceability/audit trails for ISO 9000, QS-9000 and TS 16949 reporting. Process Information Reports, Automatic Certificate of Analysis Reports and Cost of Analysis Reports are also available, not only to provide customers and auditors with the required documentation, but also to give managers a view of the profitability of the business.

## Quality Engineers Design and Monitor Global Quality Standards

Quality engineers configure the system to meet operational and user needs. Synergy 3000 seamlessly integrates with production systems such as measuring gage devices, optical comparators, Coordinate Measuring Machines (CMMs), Programmable Logic Controllers (PLCs), and Object Linking and Embedding for Process Control (OPC Server). It also intergrates with systems like Enterprise Resource Planning (ERP), Laboratory Information Management Systems (LIMs), Supervisory Control

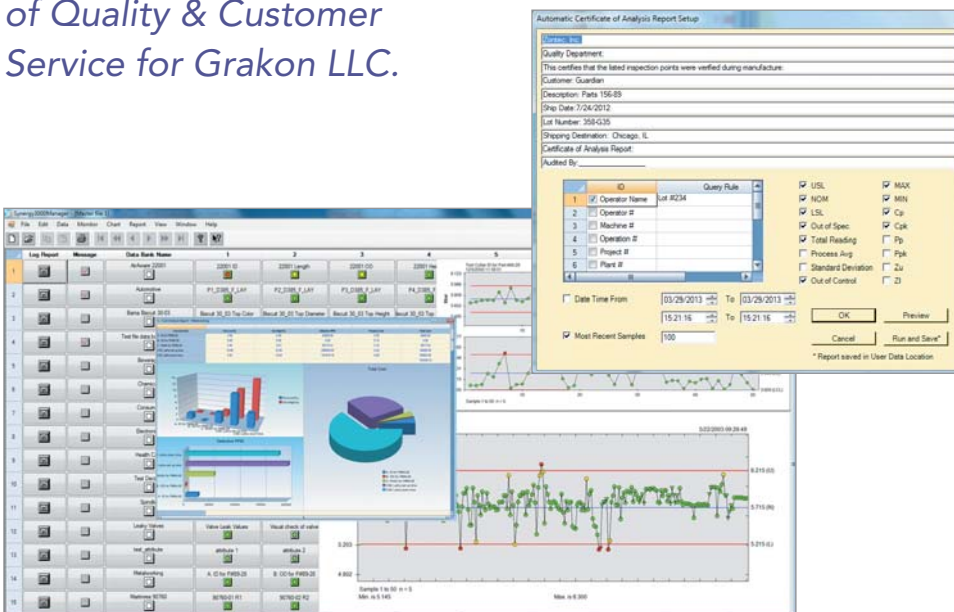

*“We use the Web Operator and Manager applications with our sister companies in China and Bulgaria as well as our main suppliers,” said Fedele D’Alessandro, General Manager for LMPsrl.*

and Data Acquisition (SCADA), Manufacturing Execution Systems (MES), or applications like Customer Relationship Management (CRM), Supply Chain and others in your production environment. The engineer can also design the screen layout that best fits the needs of the operators, while retaining access to all the data they need for Six Sigma or Lean initiatives. “If there is something new the packaging engineer wants to do, I can set it up quickly,” said Tim Stutzman, System Analyst for Oregon Freeze Dry, Inc.

Synergy 3000 provides sophisticated SPC calculations. Engineers can utilize the various methods and multiple ranges for calculating control limits to analyze process capability. If more in depth statistical regression analysis is needed, Synergy 3000 integrates with both Statgraphics® and Minitab®.

## Versatile Charting

Synergy 3000 has numerous real-time charting options for engineers so they can constantly maintain a pulse on the production process worldwide. They can gain instant access to Variable Charts, Run Charts, Histograms, Capability Charts, Attribute Charts, Overlay Charts, and Box and Whisker Charts. Six Sigma Capability Charts are also available. Additionally, the 3 Chart option allows engineers to simultaneously display Xbar, Moving Range and Range Charts. Engineers can also generate charts on user selected or queried data. With Pareto Charts, engineers can track assignable causes and corrective actions taken in response to process variation.

Synergy 3000 also helps with new product development. “The packaging engineer uses Synergy to help him determine whether or not existing machines can make a new product. He will do a test run, enter the SPC data into the system, and then using the graphing capability in Synergy 3000, will test whether or not the machine is capable or not,” said Tim Stutzman, System Analyst for Oregon Freeze Dry, Inc.

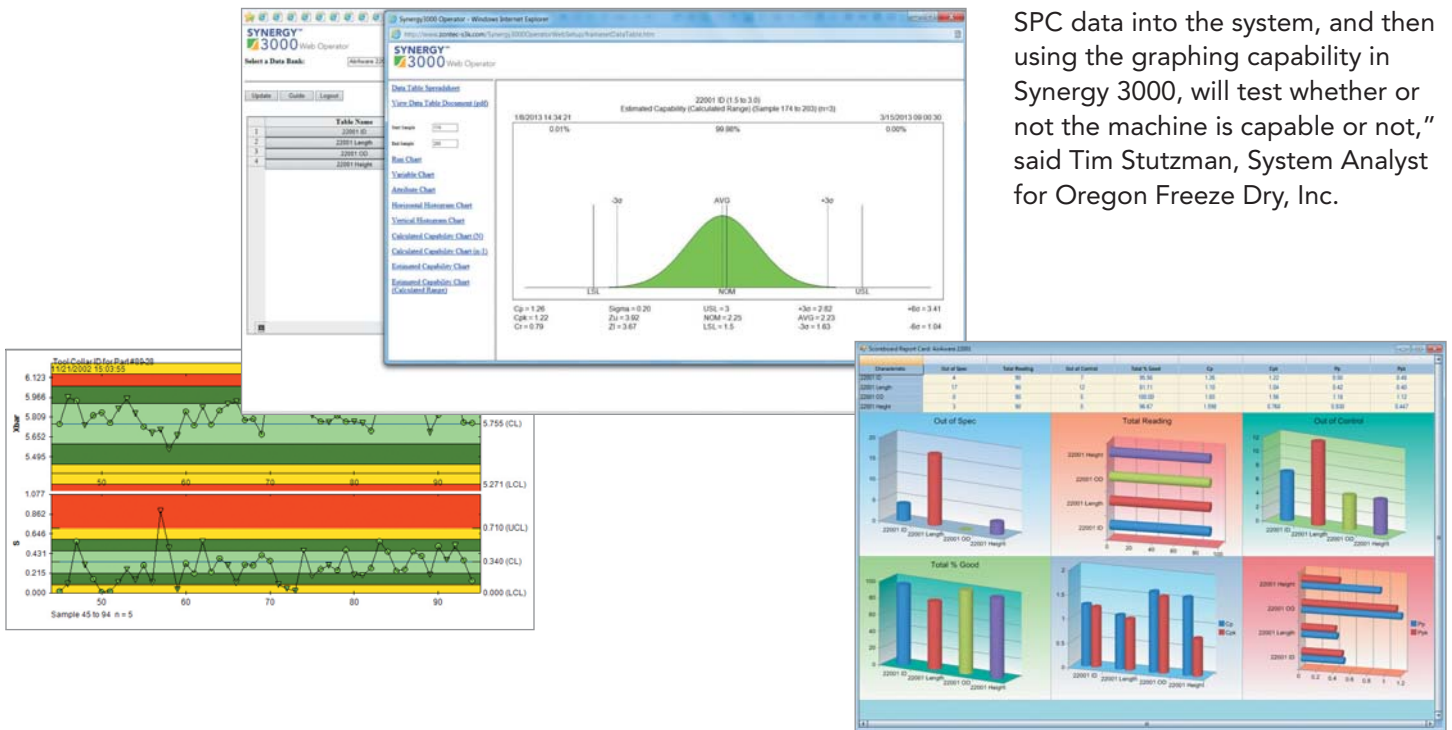

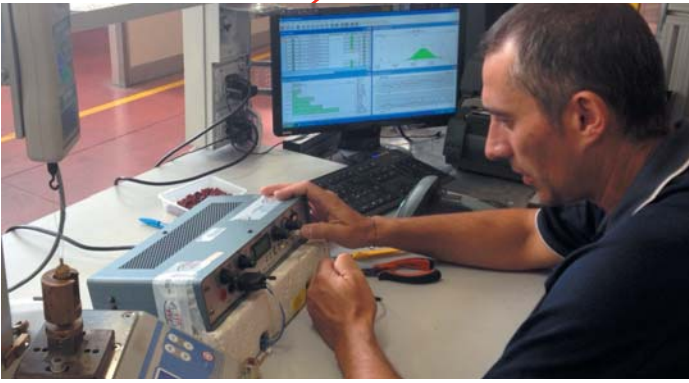

*Synergy 3000 has numerous real-time charting options for engineers so they can constantly maintain a pulse on the production process worldwide.*

## Extensive Reporting

In addition to charting, Synergy 3000 provides engineers up-to-date reports on their supply chain worldwide. All reports can be previewed, printed or emailed directly from the program. Standard reports are customizable and feature up to four charts per page. Process Information Reports, Automatic Certificate of Analysis Reports, Scoreboard Report Card Reports and Cost of Analysis Reports provide engineers with information to compare processes and determine costs associated with each process. This data can also be exported to external reporting packages such as Crystal Reports.

## Integrating Facilities and Suppliers Worldwide

With Synergy 3000 Web modules, operators, suppliers, managers, quality managers and plant managers can have worldwide access to their SPC data. Synergy 3000 Web Operator module allows operators and suppliers to enter and access data remotely. Synergy 3000 Web Manager allows managers real-time enterprise-wide monitoring of production. The Web modules allow users to perform troubleshooting and generate reports from secure remote locations (outlying plants, customer

or supplier facilities, hotels, airports or even from home). "We use the Web Operator and Manager applications with our sister companies in China and Bulgaria as well as our main suppliers," said Fedele D'Alessandro, General Manager for LMPsrl.

## About Zontec

Since 1983, Zontec is highly respected for being one of the first SPC software companies that focuses on innovation and applying new technologies that help businesses address quality issues, maximize profitability, strive for long-term continuous improvement and find new avenues for growth. Zontec is unique in the industry by offering a full suite of products to meet the needs of companies of all sizes. Zontec software has been adopted worldwide by more than 5,000 companies, spanning virtually every industrial category.

# ZONTEC

**Distributeur officiel en Europe**

**FRANCESTAT**  
**60 AVENUE CHARLES DE GAULLE**  
**92200 NEUILLY SUR SEINE**  
**FRANCE**  
**Tél : +33 (0)6 08 03 24 36**  
**Mél : [info@francestat.com](mailto:info@francestat.com)**  
**Web : [www.francestat.com](http://www.francestat.com)**

## Why Synergy 3000

What differentiates Synergy 3000 is its unique design that specifically targets each user in your entire supply chain regardless of location; from system administrators, quality engineers, managers, operators and suppliers. Synergy 3000 is designed so that each user is provided access to the level of the software that aligns with their role and responsibilities in the production process. At Zontec, we recognize the need for global companies to integrate all data into one system – data about the raw materials that arrive on your dock to the finished product that you deliver to your customers. Synergy 3000 integrates all of these systems into a single, industry-standard SQL database that provides access to your entire world-wide supply chain. "Since using Synergy 3000, we have reduced our scrap rate by 20%. We now know where we had waste in our process, realistic values to base our key performance indicators on, and how to improve our margins," said D'Alessandro. Synergy 3000 is an example of Zontec's commitment to integrating innovative technologies into its product line to enable businesses to increase profitability.



# Synergy 3000 Version 5 Features and Functions

## General Features

- Ability to define often-referenced files, documents, images, websites or other software applications as a "Hyperlink" for one click access
- Ability to modify specification limits for multiple Data Tables at once
- Ability to view control limits, specification limits, and notes all from one view
- All Charts and Reports are instantly updated, ready to preview, print, create as PDF or email
- Built using Microsoft .NET technology
- Configure default values for the number of IDs and notes fields in new Data Tables
- Customizable screen displays
- Data Reporting using Transact-SQL to query multiple databases on Microsoft SQL Server
- Each Data Bank capable of storing variable, attribute and Pareto data
- Four-level integrated system for operators, engineers, managers, system administrators
- Microsoft SQL Server database
- On-line Help facility
- Pop-up message confirming status flag reset
- Real-time SPC software quality control-based system
- Real-time Web data entry, monitoring and reporting
- Unlimited Data Banks and Tables
- View documents, drawings, PDFs and videos

## Data Acquisition and Management

- 12 customizable ID fields for traceability
- Automated input from asynchronous RS232 devices, USB or software applications
- Automatic date/time stamping upon data entry
- Automatic data export to text
- COM port interface for testing gage connections with channel number
- Customizable ID labels
- Data Bank Map
- Data Bank/Data Table Template
- Data Boundaries (gates)
- Data Log for tracking changes and deletions to data with annotation of original data
- Export data using copy/paste function
- Multiple data input options
- Notes fields for assignable cause and corrective action
- Powerful data query by ID, date/time, assignable cause, corrective action and status
- "Set ID" for automatically stamping an ID tag to each sample for traceability and query purposes. With "Auto ID", all samples will be stamped with that ID
- SQL database support for SQL Server®
- Support for multiple gage input
- "Translate Keywords" function into foreign language or industry-specific terminology
- Variable data sample size  $n = 1$  to 25

## Charting

- 3 Chart that displays Xbar, Moving Range and Range Charts
- Attribute Control Charts ( $p$ ,  $np$ ,  $c$ ,  $u$ , Pareto)
- Box and Whisker Chart generated for each observation within a Data Table
- Capability Charts with Six Sigma display
- Charting on a range of data
- High/Low Run Charts
- Overlay Charts
- Pareto, Composite Pareto and Notes Pareto Charts
- Rainbow Control Chart
- Run (pre-control) Charts
- Variable Control Charts (Xbar & R, Xbar & S, Median & R, X & Moving R)
- Variable Chart with Spec Limit for  $n=1$  (Snapshot)
- Vertical and Horizontal Histograms
- View additional information about a specific data point on Variable and Run Charts by rolling over with the mouse
- User-defined Y-axis for Control, Run Charts

## Calculation and Analysis

- Capability studies providing calculated capability ( $n$  or  $n-1$ ), estimated capability with or without calculated range
- Change date/time
- Control limit calculation on up to three ranges of data
- Easy interface with any Windows-based software application
- Enhanced Control Trend Test alarm settings for up to 20 consecutive points up, down or on one side of the center line
- Estimated or calculated sigma for control limit and process capability calculation
- Full charting capabilities on query results
- Historical analysis or charting on entire data
- Hundreds of process characteristics displayed at a time
- Interface to Statgraphics® and Minitab™
- Math calculator for avg, max, min, TIR, true position, OEE, RTY, short run, net weights and custom formulas
- Modifiable specification trend settings
- Multi-characteristic control limit calculation
- Pareto analysis on attribute data
- Pop-up warning for Control Trend Test when non-random patterns occur in the data
- Query feature to "slice and dice" data by ID fields, notes fields, date/time and status
- Real-time Control Trend Analysis
- Real-time Notes Pareto
- Test for normality
- Traceability and audit trails for ISO 9000, QS-9000 and TS 16949
- Unilateral or bilateral specifications defined and charted

## Enterprise-wide Monitoring and Communication

- Active/inactive process status indicators at Manager Level

- Adjustable Manager Level system timer for updating latest process conditions on the network
- Automatic Data Log posting for every out-of-control condition at Engineer and Manager Levels
- Data Change Log with annotation of original data
- Instant email for out-of-control conditions
- Integrated messaging system for communicating internally
- Manager Level out-of-control, out-of-spec warning when the system window is minimized
- Worldwide monitoring of data collection, charts and process status from any Manager Level workstation

## Reporting

- Automatic Certificate of Analysis Report
- Certificate of Analysis Report
- Comprehensive traceability/audit trail for ISO 9000, QS-9000 and TS 16949
- Cost of Analysis Report that calculates designated process costs
- Customizable Standard Reports that display four charts on one page
- Log Report
- Manager-Level Reports (Monthly Summary, Summary by IDs, Date/time, Samples, Monthly Reject, Reject by IDs, Date/time, Samples, Cp/Cpk, Box and Whisker Plot)
- Process Information Report
- Scoreboard Report Card Report that shows up to six processes instantly

## Web Operator Application

- Charts – Capability ( $Cp$ ,  $Cpk$ ,  $Pp$ ,  $Ppk$ ), Run, Variable, Attribute ( $p$ ,  $np$ ,  $c$ ,  $u$ ), Control, Vertical and Horizontal Histograms
- Color-coded status flags for immediate feedback
- On-line viewing of PDF procedural documents and visual aids
- Out-of-control email and text message alerts to designated customer and supplier contacts
- Real-time spreadsheet data entry
- Traceability of tag fields, notations of corrective actions and assignable causes

## Web Manager Application

- Active/inactive process indicators
- Charts – Capability ( $Cp$ ,  $Cpk$ ,  $Pp$ ,  $Ppk$ ), Run, Variable, Attribute ( $p$ ,  $np$ ,  $c$ ,  $u$ ), Control, Vertical and Horizontal Histograms
- Enterprise-wide dashboard monitoring for unlimited remote processes
- Integrated messaging with Message Log
- Networked communication among staff: Quality Control, engineering and Management
- Real-time spreadsheet display of process/quality data
- Reports (Process Information, Certificate of Analysis, Management for monthly summaries and rejects, Cp/Cpk, Box & Whisker Plot)